

**MONROE COUNTY PUBLIC LIBRARY
BOARD OF TRUSTEES**

**WORK SESSION
December 9, 2015
5:45 p.m.
Meeting Room 1B**

AGENDA

1. Call to Order –Valerie Merriam, President
2. CATS Memo of Understanding with WFHB – Michael White (page 1-3)
3. 2016-2018 Technology Plan – Ned Baugh, Marilyn Wood (page 4-27)
4. 2016 Holiday Schedule, 2016 Pay Schedule, 2016 Salary and Wage Schedule, Resolution – Kyle Wickemeyer-Hardy, Marilyn Wood (page 28-31)
5. 2016 Fines & Fees Schedule – Gary Lettelleir (page 32)
6. 2016 Board meeting dates – Marilyn Wood (page 33)
7. Public Comment
8. Adjournment

View the Board Packet on the Library's website:

<http://mcpl.info/library-trustees/meetings>

**Memorandum of Understanding between
Monroe County Public Library and
Community Radio WFHB**

This agreement outlines the details of a joint continuing initiative to be undertaken by Bloomington Community Radio WFHB (WFHB) and the Monroe County Public Library through CATS.

Between _____ and _____, the two organizations will produce a weekly program focusing on primary issue(s) in Monroe County, based on content acquired from CATS coverage of local government meetings. The program shall be telecast on the CATS network. In addition, CATS agrees that the program will be both streamed and archived on the CATS website.

The weekly news program shall be a joint undertaking of WFHB and the Monroe County Public Library through CATS. Each party to this agreement shall carry out the following responsibilities:

Monroe County Public Library through CATS will provide:

1. Footage collected during CATS' regular coverage of local government meetings
2. Other relevant CATS material
3. Studio production services, including equipment and facilities necessary to produce and create the half-hour program.
4. Weekly telecasts of the program on CATS channels 3, 12 and 14
5. A schedule of government meetings each week
6. The sum of \$12,000, which shall be payable to WFHB in four installments from the Library's Special Revenue Fund and not from funds received from property tax revenues. WFHB shall have access to deposited funds for any use in the ordinary and usual course of WFHB business.

WFHB will provide:

1. An anchor for the telecast, if needed
2. A hyperlink to CATSWeek on the catstv.net website on all postings of episodes of the *Daily Local News* that employ stories for CATSWeek on WFHB's website.
3. A staff person assigned to coordinate and produce the program
4. Additional WFHB volunteers
5. On-air in-kind underwriting: WFHB agrees to air one on-air ad for CATS each and every day of the calendar year (value: \$4,380). This ad shall consist of a 20-second live read performed by on-air hosts, drawing from a rotation of up to six scripts written by the CATS general manager and approved by the WFHB general manager.

The Monroe County Public Library and WFHB agree that the editorial decisions shall be determined as a result of consultation between the CATS general manager and the WFHB general manager.

WFHB and Monroe County Public Library and CATS agree that the final show as produced and telecast shall become the property of the Monroe County Public Library and CATS and the appropriate acknowledgment of this ownership shall be stated in the credits for each show. The program shall be archived and retained in the same manner as all CATS programs.

The Monroe County Public Library, CATS and WFHB acknowledge that each party will direct their employees to meet their obligations under this agreement. Each party to this agreement shall be responsible for compensating the employees which they use to meet their obligations under this agreement. Monroe County Public Library, CATS and WFHB acknowledge that neither shall be responsible for nor share any liability for compensating the employees other than those under their employ.

The Monroe County Public Library, CATS and WFHB each acknowledge that no party to this agreement shall have a cause of action against any other party of this agreement as a result of the production of the news program. Each party to this agreement shall be responsible for obtaining all necessary insurance coverage to protect and indemnify them from any liability which they may incur as a result of participation under this agreement. Each party to this agreement shall be responsible for and meet their obligations as the employer of any employee who may provide services under this agreement and shall have no cause of action against the other party of this agreement for any cause of action brought against them by any employee providing services to an employer under this contract.

Each party to the agreement shall further secure a waiver of subrogation from any insurer providing insurance required hereunder.

All parties under this agreement acknowledge that this agreement may be amended only in writing and if such amendments are approved by the Monroe County Public Library Board of Trustees and the WFHB Board of Directors.

WFHB, Monroe County Public Library and CATS acknowledge that this agreement may be terminated at any time. Notice of termination shall be mailed at least 30 days in advance of the termination to the individuals listed below representing the other party:

Cleveland Dietz II, General Manager
WFHB Community Radio
108 W. 4th St.
Bloomington, IN 47404

Michael White, Manager
CATS/Monroe County Public Library
303 E. Kirkwood Ave.
Bloomington, IN 47408

Marilyn Wood, Director
Monroe County Public Library

303 E. Kirkwood Ave.
Bloomington, IN 47408

The parties further agree that this agreement may be renewed on an annual basis upon approval by the governing bodies of each party.

_____, President
WFHB Community Radio
Board of Directors

Date: _____

Cleveland Dietz II, General Manager
WFHB Community Radio

Date: _____

_____, President
Board of Trustees
Monroe County Public Library

Date: _____

Michael White, General Manager
Community Access Television Services

Date: _____

Monroe County Public Library

Three Year Technology Plan 2016 to 2018

Table of Contents

Executive Summary.....	1
Background Information	2
Library Overview:.....	2
Mission Statement:	2
Vision Statement:.....	2
Assessment of Technology Resources	2
Progress on 2013-2015 Plan	3
Current State of Technology	4
Library’s Technology Mission, Vision, Goals	6
Technology Mission:	6
Technology Vision:	6
Goals and Realistic Strategies	7
Professional Development Strategy	7
Equipment Replacement Schedule	8
Financial Resources.....	10
Evaluation	13
Automation Plan	13
Appendices	

Executive Summary

Technology is critically tied to the mission and vision of the Monroe County Public Library. We strive to most effectively identify appropriate technology, ensure a robust technological infrastructure, and develop an informed and technologically savvy staff. To that end, we utilize the following approach: investigation of new technologies as they become available; assessment of their usefulness to the accomplishment of our mission; appropriate utilization by equipping our staff with the best tools and training that we can provide; and provision of technology services and training to our customers to ensure we meet their 21st century literacy needs.

This document includes a brief review of technology progress since the 2013-2015 Technology Plan; an assessment of the library's current technology needs and challenges; assessment of the library's technology needs driven by our strategic plan and community need; technology mission, vision, goals and timeline; a description of our professional development strategy; a projected technology budget; a technology network diagram; and an equipment inventory.

Background Information

Library Overview:

The Monroe County Public Library serves 143,339 residents of Monroe County, Indiana, home of Indiana University. The library provides service through a Main Library in downtown Bloomington, a branch in Ellettsville, and outreach services including a bookmobile, homebound, van, and jail service. In addition to comprehensive library services, the library also hosts homework help, an active adult literacy program, and a community access television station with five channels.

The library enjoys strong community support and is consistently ranked among the top ten public libraries of its size in the country. In 2014, circulation exceeded 2.5 million items and patrons made more than a million visits, and used 175,669 computer sessions. 57,864 people participated in 2,225 library programs and the library hosted 1,565 meetings of local community groups.

The library Board has taxing authority, limited by state law and review by County Council. In 2015, the library had an operating budget of nearly \$8 million. Also in 2015, the library secured a three-year \$1.995 million general obligation bond that will help the library keep its facilities and technology current.

Mission Statement:

The mission of the Monroe County Public Library is to enrich lives and strengthen our community by providing equitable access to information and opportunities to read, learn, discover, and create.

Vision Statement:

An educated, engaged, curious, and creative Monroe County, with the library at its center.

Assessment of Technology Resources

The 2013-2015 Technology Plan included three goals, all which were articulated in the Library's 2013-2017 Strategic Plan:

- Strengthen 21st Century Literacy Skills
- Provide Shared Access to the World's Information for Free
- Optimize Stewardship of Library Resources

Work toward these goals included a number of activities to strengthen technology availability to Library customers and staff, engagement with the community through technology, and focused attention on infrastructure needs to support technical improvements and staff development.

Progress on 2013-2015 Plan

The 2013-15 plan identified 15 areas for review and enhancement. Progress was made in each area and is outlined below:

1. Optimization of network setup to improve data security, speed, etc.
The library replaced its aging network infrastructure with new equipment, increasing overall network capacity and allowing for a new Voice over IP (VoIP) telephone system. This also prepared for expanded wireless coverage for both staff and patrons. Additionally, the new network allowed for increased security for staff data, separating patron network traffic. Implementation of a drive-based backup system at the Ellettsville branch to automate server backups to this offsite location also occurred.
2. Replacement of aging telephone system.
The Library moved from an outdated digital system to Voice over IP (VoIP). This work included replacing the server equipment as well as all the handsets at the Main Library and Ellettsville.
3. Upgrade to Polaris 4.1 and initiating use of community organizations functionality.
Polaris software was updated.
4. Installation of patron self-service scanning.
Customers can now scan documents for free and save them to USB, Google Drive, send to email or fax at both the Main Library and Ellettsville branch.
5. Wi-Fi access to the public 24/7.
The Library increased coverage throughout both locations, and added outside coverage at the Main Library.
6. Wireless printing for the public.
Implemented.
7. Continued attention to and improvements to website and accessibility issues.
The Library completed a migration of its web sites (public and intranet) to cloud-hosted service.
8. Defining and documenting a replacement cycle for various equipment.
A full inventory and replacement cycle for equipment was implemented.
9. Creation of a digital creativity center and teen center along with new technology in that space.
These spaces were constructed and technology includes soundproof audio recording studios, a green-screen enabled video studio, iMac and Windows workstations, laptops and iPads available for use in the space, video game consoles, teens-only hang out areas, and a Makerspace.
10. Addressing audio/video/sound equipment in auditorium and meeting rooms during renovation.
The auditorium systems were updated and improved; one new meeting room was constructed and equipped.
11. Investigation of new productivity tools for staff (scheduling for staff, email functionality, project management tools, etc.).
The Library upgraded to the current version of Evanced calendar scheduling software for the Library's public events calendar, and implemented D!bs room reservation for recording studios and small meeting rooms.
12. Investigation of and possible implementation of a discovery layer.
Under continuous review.

13. Investigation of use of a data farm to facilitate a coordinated data collection and reporting environment.

This was not implemented although a more organized structure for statistics gathering and reporting is in place.

14. Investigation of and possible implementation of additional assistive technologies to better meet the needs of persons with disabilities.

Loop audio system was installed in the auditorium. Training sessions with staff to increase awareness of assistive technologies available, and added information to our website about these products.

15. Support for furthering digitization efforts, including increasing storage capacity.

Storage capacity was increased and systems for back-up were implemented.

16. Increase web access to CATS, digitize CATS archive content, upgrade CATS signal to HD, work with partners to upgrade facilities to HD.

Partner facilities have been upgraded to support HD, web access has been improved, and new workflows created to accommodate HD content. Planning and initial implementation of the move to HD-fiber system has taken place.

Current State of Technology

The following is a brief overview of the library's current state of technology.

Tools and applications for providing service to the public:

- Polaris 4.1 and self-check out: In addition to staff assisted check-outs, we offer self-check stations; personal account information available online; email, phone and text messaging features for circulation, holds, and billing.
- Automated Material Handling system automatically checks in and sorts to collection type more than 2 million items each year.
- Public computing hardware that includes 20 public catalog computers, 7 workstations for digital creativity use in Level Up, 4 workstations and 8 laptops for use in The Ground Floor teen area, and 80 general use workstations with access to printing, managed by EnvisionWare time management system.
- Audio and video equipment and software including among other things: iMac computers, headphones, microphones, digital piano, digital drums, camcorders, cameras, tele-prompters, Adobe suite and editing software. PlayStation 4, Wii, laptops, iPads for patron use.
- Public computing software including at least: Windows 7 Pro, Office 2013, Firefox, and Chrome.
- Open Wireless access at the Main Library and Ellettsville branch.
- Evanced meeting room scheduling facilitates registration of auditorium and meeting rooms for both patrons and staff and website display of scheduled library events and programs.

Monroe County Public Library Three Year Technology Plan 2016 to 2018

- Public website running on Drupal open-source software, provides access to the library catalog, meeting room events calendar and booking, commercial databases, in-house databases, research tools, personal library account information, staff recommendations and more.
- Databases & Digitization of local content including subscription databases and those which are developed in-house.
- Photocopiers for public and staff use.
- Auditorium and meeting room audio and visual equipment including ceiling mounted and portable devices.
- Drop-in help and one-on-one technology assistance for patrons.

Staff tools at a minimum now include:

- Staff workstations: 204
- Windows 7 Pro and Windows 10 Pro, Mac OSX, Microsoft Server 2008-12, Red Hat Linux
- IIS, Apache, MS-SQL, MySQL, Drupal
- Microsoft Office 2013 Professional Suite
- Firefox, Chrome, and Opera web browsers
- Staff intranet – Drupal-based internal website
- Graphics equipment – Adobe Creative Suite, Color Printing, Scanning, Lamination
- OCLC cataloging and database
- Spiceworks application for IT Help Desk ticket management and equipment inventory

Business applications:

- ECI Time Management and Payroll system
- Banyon Financial system

Telecommunications, Servers and Internet Service:

- Wireless access at Main and Ellettsville
- 200 Mbps Internet shared by Main and Ellettsville locations
- Dark fiber connection between Main and Ellettsville locations
- VoIP Telephone system, including voice mail, automated message handling, outgoing after-hours message

Safety and Security:

- Security Cameras and associated equipment
- RFID Tagging and Security Gates

Community Partnership Support Applications:

Monroe County Public Library Three Year Technology Plan 2016 to 2018

- CATS. The Library hosts the Community Access Television Service (CATS), which maintains five cable television channels, produces independent community programming, supports patrons in creating programming, and delivers live and archived content via the web.

Compliance with 590 IAC 6-1-4 Minimum Standards for Public Libraries:

The library complies with Indiana's minimum standards for public libraries, as related to technology, including:

- A telephone listed in the library's name.
- Voice mail or similar technology to provide operating hours of the library.
- An email address or other means of electronic communication for the library via the library's website.
- A means to provide copies to the public at each location.
- Technology to transmit documents electronically (fax), or email through use of scanner.
- A website including:
 - Hours of operation, addresses, maps, phone numbers and email addresses.
 - Electronic resources provided free of charge (including INSPIRE)
 - The library's online public access catalog.
 - A calendar of events and programs, updated regularly.
- An integrated library system with an online public access catalog available on the library's website.
- Internet connectivity of at least 1.5Mbps.
- Staff computers with office software, printing and internet access.
- At least one public access computer connected to the Internet per two thousand served (Library provides at least 80 computers for a population of 143,000).
- Wireless Internet access for patrons MCPL provides Wi-Fi at the Main Library and Ellettsville.

Library's Technology Mission, Vision, Goals

Technology Mission:

The mission of technology is to support the Library's strategic plan by maintaining technology infrastructure to maximize access to information, educating staff and patrons about technology and its uses, and playing a key role in library innovation.

Technology Vision:

The Library's technology vision is a community which is technologically literate and has abundant access to current technology and information resources.

Goals and Realistic Strategies

These goals and strategies represent the Library's effort to maintain a technologically rich environment for Monroe County Public Library users. These goals are represented in our strategic plan and the activities below will be conducted during this Technology Plan period.

Goal: Strengthen 21st Century Literacy Skills

Strategies:

- Provide equipment and support for digital creativity.
- Improve access to and satisfaction with electronic media (e-books, digital audio).
- Expand web content to include technology literacy and children's library programming.

Goal: Provide Shared Access to the World's Information for Free

Strategies:

- Increase community engagement via social media, e-newsletter.
- Increase awareness and use of online databases, enhance mobile access for library services, continue to improve library technology infrastructure.
 - Migrate remaining analog technology in CATS to digital, including necessary infrastructure improvements. This infrastructure will support the acquisition, playback and storage of a high definition, all-digital collection of programming.
- Where appropriate, migrate to new technologies for staff.
 - Migrate to cloud-based email and document-sharing service in 2016 to augment and/or replace onsite email system.
 - Migrate to virtualized server environment for onsite servers (Polaris, terminal services, file sharing) to provide better fault tolerance and efficiency.
 - Continue to review productivity tools and implement as appropriate.

Goal: Optimize Stewardship of Library Resources

Strategies:

- Train staff to effectively represent the library in the community.
- Continuously expand staff technology mastery.
- Update maintenance and replacement schedules for technology, including an upgrade to the Library's server room UPS equipment.
- Explore improvements in backup and disaster recovery planning.

Professional Development Strategy

The following goals and strategies represent the library's commitment to provide staff members who are knowledgeable about technology concepts and practices.

Staff development strategies to support the technology goals are included in individual staff and departmental work plans as well as the overall staff development plan for the library. Managers are responsible for providing the resources, support and training necessary to ensure completion of goals.

Goal: Ensure library staff have appropriate general computer skills, as well as appropriate knowledge of library applications and tools.

Strategies:

- Training provided for transitioning to new technologies (Cloud computing).
- Training provide for new technologies as they become available – audio/video/graphics production, editing, programming, etc.
- Staff will be encouraged to explore new technologies to evaluate their potential for enhancing library services.
- Core Competency Checklists including tailored technology section for each position/service area will be created. Update checklists as new services are added.
- Managers maintain “expert list” of assigned staff who take leadership in watching for and communicating changes in library tools (such as databases and downloadable services). Annual review or with implementation of service changes as needed.
- Assigned “Experts” maintain and update procedures and documentation on Intranet annually or with implementation of changes in the service as needed.
- Staff Development Strategist features classroom instruction and/or online learning that qualifies for TLEU at least every other month, including orientation basic topics and more expert user features.
- Staff Development Strategist maintains “Peer-Recommended” webinars list for independent learning/discovery including technology topics. Monthly review or as needed to add additional content.
- Staff working in Digital Creativity area (Level Up) complete assigned Lynda.com “Playlist” focusing on software available to patrons. Each staff member completes the list within 9 months of orientation in this service area.
- The Leadership Team creates a template for an “Implementation Checklist” of any new/greatly changed technology (such as ILS upgrade, transition to cloud computing.) Checklist will feature a training component and be used for each subsequent new/updated service.
- Continued commitment to overall Staff Development Plan to allocate at least one hour of training time each month for each full time employee, prorated for part time employees.

Goal: Ensure library staff have appropriate skills to provide technical support to patrons and staff. This includes IT, website, network infrastructure and workstation support.

Strategies:

- Appropriate documentation of procedures.
- Staff training as new technologies become available.
- Evaluation of new technologies.

Equipment Replacement Schedule

Generally, we strive to replace all computer hardware based on the following guidelines:

Monroe County Public Library Three Year Technology Plan 2016 to 2018

- Notebook Computers 3-4 years
- Desktop Computers 3-4 years
- Servers 3-5 years
- Network Equipment 3-5 years
- Printers (as needed) 5+ years

Financial Resources

2016

	Operating Fund	Special Revenue	General Obligation Bond	TOTAL Budget 2016
IS Staff Salaries	\$154,836.00			\$154,836.00
IS Staff Benefits	\$62,272.00			\$62,272.00
IS Supplies	\$6,000.00			\$6,000.00
IS Equipment			\$85,000.00	\$85,000.00
IS Software			\$25,000.00	\$25,000.00
IS Maintenance Contracts or Services	\$88,000.00			\$88,000.00
IS Consulting Services	\$5,000.00			\$5,000.00
Telephone Service Contracts/Equipment	\$21,000.00			\$21,000.00
Internet Service	\$25,000.00			\$25,000.00
OCLC Services	\$43,000.00			\$43,000.00
Dues/Institutional	\$200.00			\$200.00
Educational/Licensing Services				\$0.00
Real Estate Rental/Park	\$2,000.00			\$2,000.00
CATS Equipment		\$45,000.00	\$45,000.00	\$90,000.00
CATS Software			\$5,000.00	\$5,000.00
CATS Telephone	\$2,300.00	\$3,000.00		\$5,300.00
CATS Internet Service	\$1,500.00			\$1,500.00
CATS Digitization services		\$11,000.00		\$11,000.00
CATS video Tape		\$5,000.00		\$5,000.00
CATS Video Materials		\$10,000.00		\$10,000.00
CATS IS Supplies		\$1,200.00		\$1,200.00
CATS Consulting Services		\$10,000.00		\$10,000.00
TOTAL	\$411,108.00	\$85,200.00	\$160,000.00	\$656,308.00

Monroe County Public Library Three Year Technology Plan 2016 to 2018

2017

	Operating Fund	Special Revenue	General Obligation Bond	TOTAL Budget 2017
IS Staff Salaries	\$157,932.72			\$157,932.72
IS Staff Benefits	\$65,385.60			\$65,385.60
IS Supplies	\$6,000.00			\$6,000.00
IS Equipment			\$85,000.00	\$85,000.00
IS Software			\$25,000.00	\$25,000.00
IS Maintenance Contracts or Services	\$89,760.00			\$89,760.00
IS Consulting Services	\$5,000.00			\$5,000.00
Telephone Service Contracts/Equipment	\$21,000.00			\$21,000.00
Internet Service	\$25,000.00			\$25,000.00
OCLC Services	\$43,000.00			\$43,000.00
Dues/Institutional	\$200.00			\$200.00
Educational/Licensing Services				\$0.00
Real Estate Rental/Park	\$2,000.00			\$2,000.00
CATS Equipment		\$45,000.00	\$45,000.00	\$90,000.00
CATS Software			\$5,000.00	\$5,000.00
CATS Telephone	\$2,300.00	\$3,000.00		\$5,300.00
CATS Internet Service	\$1,500.00			\$1,500.00
CATS Digitization services		\$11,000.00		\$11,000.00
CATS video Tape		\$5,000.00		\$5,000.00
CATS Video Materials		\$10,000.00		\$10,000.00
CATS IS Supplies		\$1,200.00		\$1,200.00
CATS Consulting Services		\$10,000.00		\$10,000.00
TOTAL	\$419,078.32	\$85,200.00	\$160,000.00	\$664,278.32

Monroe County Public Library Three Year Technology Plan 2016 to 2018

2018

	Operating Fund	Special Revenue	General Obligation Bond	TOTAL Budget 2017
IS Staff Salaries	\$161,091.37			\$161,091.37
IS Staff Benefits	\$68,654.88			\$68,654.88
IS Supplies	\$6,000.00			\$6,000.00
IS Equipment			\$85,000.00	\$85,000.00
IS Software			\$25,000.00	\$25,000.00
IS Maintenance Contracts or Services	\$91,555.20			\$91,555.20
IS Consulting Services	\$5,000.00			\$5,000.00
Telephone Service Contracts/Equipment	\$21,000.00			\$21,000.00
Internet Service	\$25,000.00			\$25,000.00
OCLC Services	\$43,000.00			\$43,000.00
Dues/Institutional	\$200.00			\$200.00
Educational/Licensing Services				\$0.00
Real Estate Rental/Park	\$2,000.00			\$2,000.00
CATS Equipment		\$45,000.00	\$45,000.00	\$90,000.00
CATS Software			\$5,000.00	\$5,000.00
CATS Telephone	\$2,300.00	\$3,000.00		\$5,300.00
CATS Internet Service	\$1,500.00			\$1,500.00
CATS Digitization services		\$11,000.00		\$11,000.00
CATS video Tape		\$5,000.00		\$5,000.00
CATS Video Materials		\$10,000.00		\$10,000.00
CATS IS Supplies		\$1,200.00		\$1,200.00
CATS Consulting Services		\$10,000.00		\$10,000.00
TOTAL	\$427,301.45	\$85,200.00	\$160,000.00	\$672,501.45

Evaluation

Our strategic goals and strategies are incorporated into department work plans and individual staff work plans and performance expectations are set and measured annually with review at least bi-annually.

Additional improvement methods to be incorporated into IT services during this plan:

1. Development of a Service Level Agreement for IT.
2. Evaluation of help desk ticketing system reports.
3. Ongoing documentation for equipment, services and procedures in IT.

This technology plan will be reviewed and approved by the Library Board. Ongoing evaluation occurs at least annually within the Information Technology Unit to ensure movement toward goals. Certain strategies described above require evaluation more frequently.

Automation Plan

The library currently uses the Polaris ILS to manage catalog and patron data, which conforms to national cataloging standards.

Appendix A: Network Diagram

Appendix B: Equipment Inventory

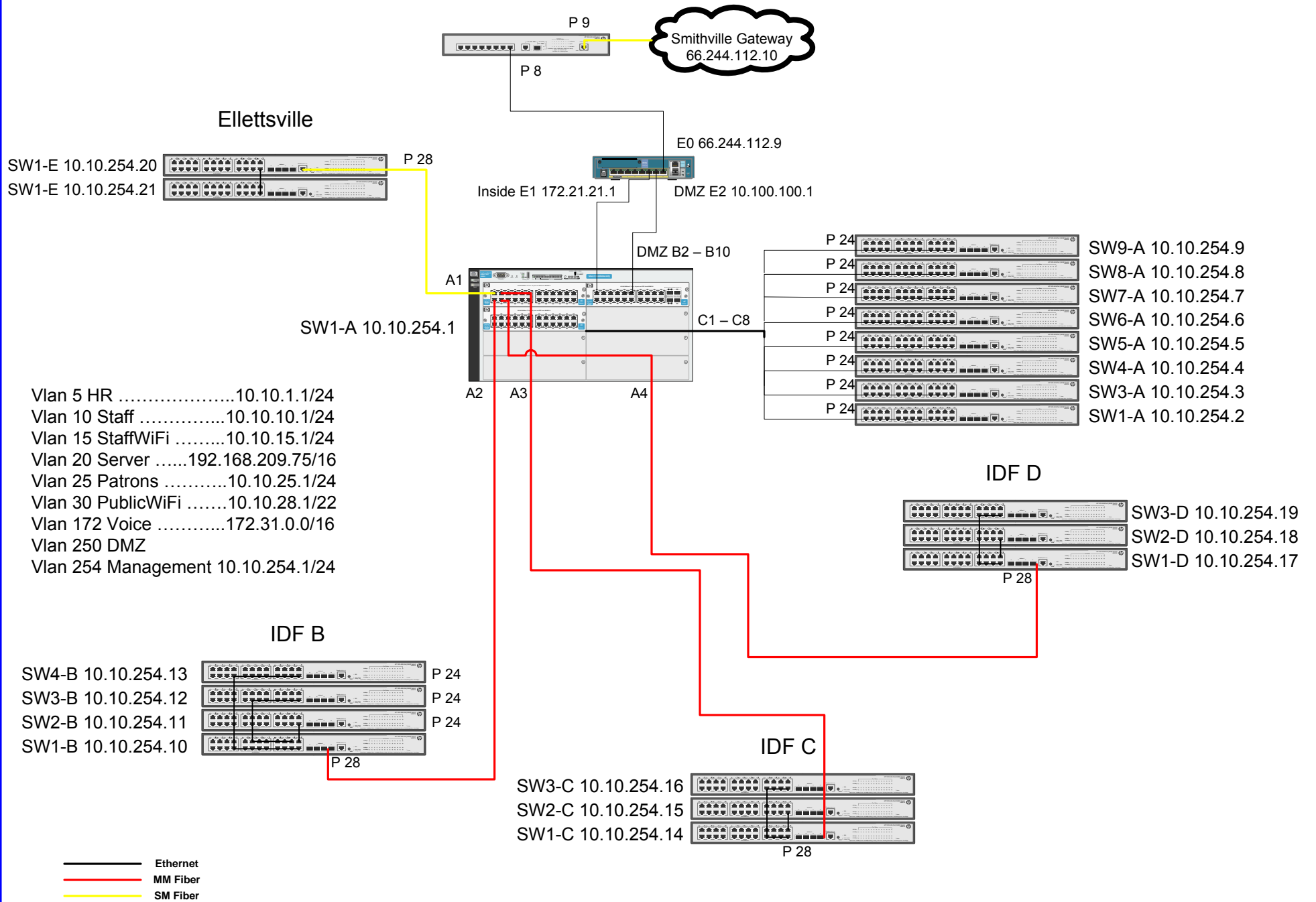

- Vlan 5 HR 10.10.1.1/24
- Vlan 10 Staff 10.10.10.1/24
- Vlan 15 StaffWiFi 10.10.15.1/24
- Vlan 20 Server 192.168.209.75/16
- Vlan 25 Patrons 10.10.25.1/24
- Vlan 30 PublicWiFi 10.10.28.1/22
- Vlan 172 Voice 172.31.0.0/16
- Vlan 250 DMZ
- Vlan 254 Management 10.10.254.1/24

IDF B

- SW4-B 10.10.254.13 P 24
- SW3-B 10.10.254.12 P 24
- SW2-B 10.10.254.11 P 24
- SW1-B 10.10.254.10 P 28

IDF D

- SW3-D 10.10.254.19 P 28
- SW2-D 10.10.254.18
- SW1-D 10.10.254.17

IDF C

- SW3-C 10.10.254.16 P 28
- SW2-C 10.10.254.15
- SW1-C 10.10.254.14

— Ethernet
 — MM Fiber
 — SM Fiber

Appendix B

Technology Inventory

Device Type Name		Used As	Manufacturer	Model
Desktop	olderopac03	Catalog Computer	Hewlett-Packard	dx2400 Microtower
Desktop	oldopac25	Catalog Computer	Hewlett-Packard	dx2400 Microtower PC
Desktop	opac02	Catalog Computer	Hewlett-Packard	dx2400 Microtower
Desktop	opac03	Catalog Computer	Hewlett-Packard	dx2400 Microtower
Desktop	opac07	Catalog Computer	Hewlett-Packard	dx2400 Microtower
Desktop	opac08	Catalog Computer	Hewlett-Packard	AY014AAR-ABA a4310f
Desktop	opac09	Catalog Computer	Hewlett-Packard	dx2400 Microtower
Desktop	opac101	Catalog Computer	Hewlett-Packard	dx2400 Microtower
Desktop	opac102	Catalog Computer	Hewlett-Packard	dx2400 Microtower
Desktop	opac14	Catalog Computer	Hewlett-Packard	Pro 3130 Microtower PC
Desktop	opac15	Catalog Computer	Dell	
Desktop	opac21	Catalog Computer	Hewlett-Packard	dx2400 Microtower
Desktop	opac25	Catalog Computer	Hewlett-Packard	dx2400 Microtower
Desktop	opac30	Catalog Computer	Hewlett-Packard	dx2400 Microtower
Desktop	opac33	Catalog Computer	Hewlett-Packard	dx2400 Microtower PC
Desktop	opac35	Catalog Computer	Hewlett-Packard	dx2400 Microtower
Desktop	opac37	Catalog Computer	Hewlett-Packard	dx2400 Microtower
Desktop	opac38	Catalog Computer	Hewlett-Packard	LaserJet M2727nf MFP
Desktop	opac39	Catalog Computer	Asustek Computer	
Desktop	opac42	Catalog Computer	Hewlett-Packard	dx7500 Microtower
Desktop	opac43	Catalog Computer	Hewlett-Packard	dx2400 Microtower
Desktop	opac47	Catalog Computer	Asustek Computer	
Desktop	opac48	Catalog Computer	Hewlett-Packard	AY014AAR-ABA a4310f
Desktop	opac49	Catalog Computer	Hewlett-Packard	Pro 3130 Microtower PC
Desktop	opac50	Catalog Computer	ASUSTeK COMPUTER	UN42
Desktop	opac51	Catalog Computer	ASUSTeK COMPUTER	UN42
Desktop	opac666	Catalog Computer	Hewlett-Packard	dx2400 Microtower
Desktop	opac999	Catalog Computer	Hewlett-Packard	dx2400 Microtower
Desktop	teenopac1	Catalog Computer	Hewlett-Packard	200-010
Desktop	teenopac2	Catalog Computer	Hewlett-Packard	200-010
Desktop	teen-imac-01	Ground Floor	Apple	iMac
Desktop	teen-mac-1	Ground Floor	Apple	iMac
Laptop	teen_win_01	Ground Floor	Lenovo	Lenovo C560
Laptop	teen_win_02	Ground Floor	Lenovo	Lenovo C560

Laptop	teen-laptop-01	Ground Floor	Hewlett-Packard	ProBook 450 G2
Laptop	teen-laptop-02	Ground Floor	Hewlett-Packard	ProBook 450 G2
Laptop	teen-laptop-03	Ground Floor	Hewlett-Packard	ProBook 450 G2
Laptop	teen-laptop-04	Ground Floor	Hewlett-Packard	ProBook 450 G2
Laptop	teen-laptop-05	Ground Floor	Hewlett-Packard	ProBook 450 G2
Laptop	teen-laptop-06	Ground Floor		
Laptop	teen-laptop-07	Ground Floor	Hewlett-Packard	ProBook 450 G2
Laptop	teen-laptop-08	Ground Floor	Hewlett-Packard	ProBook 450 G2
Desktop	AudioStudio1	LevelUp Computer	Apple	iMac
Desktop	AudioStudio2	LevelUp Computer	Apple	iMac
Desktop	VideoStudio	LevelUp Computer	Apple	Mac mini
Desktop	LevelUp-01	LevelUp Computer	Apple	iMac
Desktop	LevelUp-02	LevelUp Computer	Apple	iMac
Desktop	LevelUp-03	LevelUp Computer	Apple	iMac
Desktop	LevelUp-04	LevelUp Computer	Apple	iMac
Desktop	ellsorter	Materials Handling	Hewlett-Packard	rp5700 Business System
Desktop	smartreturn3	Materials Handling	G-pro Computer	
Desktop	adult01	Public Computer	Hewlett-Packard	Pro3500 Series
Desktop	adult02	Public Computer	Hewlett-Packard	Pro3500 Series
Desktop	adult03	Public Computer	Hewlett-Packard	Pro3500 Series
Desktop	adult04	Public Computer	Hewlett-Packard	Pro3500 Series
Desktop	adult05	Public Computer	Hewlett-Packard	Pro3500 Series
Desktop	adult06	Public Computer	Hewlett-Packard	Pro3500 Series
Desktop	adult07	Public Computer	Hewlett-Packard	Pro3500 Series
Desktop	adult08	Public Computer	Hewlett-Packard	Pro3500 Series
Desktop	adult09	Public Computer	Hewlett-Packard	Pro3500 Series
Desktop	adult10	Public Computer	Hewlett-Packard	Pro3500 Series
Desktop	adult11	Public Computer	Hewlett-Packard	Pro3500 Series
Desktop	adult12	Public Computer	Hewlett-Packard	Pro3500 Series
Desktop	adult13	Public Computer	Hewlett-Packard	Pro3500 Series
Desktop	adult14	Public Computer	Hewlett-Packard	Pro3500 Series
Desktop	adult15	Public Computer	Hewlett-Packard	Pro3500 Series
Desktop	adult16	Public Computer	Hewlett-Packard	Pro3500 Series
Desktop	adult17	Public Computer	Hewlett-Packard	Pro3500 Series
Desktop	adult18	Public Computer	Hewlett-Packard	Pro3500 Series
Desktop	adult19	Public Computer	Hewlett-Packard	Pro3500 Series
Desktop	adult20	Public Computer	Hewlett-Packard	Pro3500 Series
Desktop	adult21	Public Computer	Hewlett-Packard	Pro3500 Series

Desktop	adult22	Public Computer	Hewlett-Packard	Pro3500 Series
Desktop	adult23	Public Computer	Hewlett-Packard	Pro3500 Series
Desktop	adult24	Public Computer	Hewlett-Packard	Pro3500 Series
Desktop	adult25	Public Computer	Hewlett-Packard	Pro3500 Series
Desktop	adult26	Public Computer	Hewlett-Packard	Pro 3130 Microtower PC
Desktop	adult27	Public Computer	Hewlett-Packard	Pro 3130 Microtower PC
Desktop	adult28	Public Computer	Hewlett-Packard	Pro 3130 Microtower PC
Desktop	adult29	Public Computer	Hewlett-Packard	Pro 3130 Microtower PC
Desktop	adult30	Public Computer	Hewlett-Packard	Pro 3130 Microtower PC
Desktop	adult31	Public Computer	Hewlett-Packard	Pro3500 Series
Desktop	adult32	Public Computer	Hewlett-Packard	Pro3500 Series
Desktop	adult33	Public Computer	Hewlett-Packard	Pro3500 Series
Desktop	adult34	Public Computer	Asustek Computer	Generic
Desktop	adult35	Public Computer	Hewlett-Packard	dx2400 Microtower
Desktop	adult36	Public Computer	Hewlett-Packard	dx2400 Microtower
Desktop	adult37	Public Computer	Hewlett-Packard	dx2400 Microtower
Desktop	adult38	Public Computer	Hewlett-Packard	dx2400 Microtower
Desktop	adult40	Public Computer	Asustek Computer	SYX Max
Desktop	adult41	Public Computer	Hewlett-Packard	Pro3500 Series
Desktop	adult42	Public Computer	Hewlett-Packard	Pro 3130 Microtower PC
Desktop	adult43	Public Computer	Hewlett-Packard	Pro 3130 Microtower PC
Desktop	adult44	Public Computer	Hewlett-Packard	Pro 3130 Microtower PC
Desktop	adult45	Public Computer	Hewlett-Packard	Pro 3130 Microtower PC
Desktop	adult46	Public Computer	Hewlett-Packard	Pro 3130 Microtower PC
Desktop	adult47	Public Computer	Hewlett-Packard	Pro 3130 Microtower PC
Desktop	adult48	Public Computer	Hewlett-Packard	Pro 3130 Microtower PC
Desktop	adult49	Public Computer	Hewlett-Packard	Pro 3130 Microtower PC
Desktop	adult50	Public Computer	Hewlett-Packard	Pro 3130 Microtower PC
Desktop	adult55	Public Computer	Hewlett-Packard	Pro 3130 Microtower PC
Desktop	adult56	Public Computer	Hewlett-Packard	Pro 3130 Microtower PC
Desktop	adult57	Public Computer	Hewlett-Packard	Pro3500 Series
Desktop	adult58	Public Computer	Hewlett-Packard	Pro3500 Series
Desktop	adult59	Public Computer	Hewlett-Packard	Pro3500 Series
Desktop	adult60	Public Computer	Hewlett-Packard	Pro3500 Series
Desktop	children1	Public Computer	Hewlett-Packard	dx2400 Microtower
Desktop	children10	Public Computer	Hewlett-Packard	dx2400 Microtower
Desktop	children11	Public Computer	Hewlett-Packard	dx2400 Microtower
Desktop	children2	Public Computer	Hewlett-Packard	dx2400 Microtower

Desktop	children3	Public Computer	Hewlett-Packard	dx2400 Microtower
Desktop	children4	Public Computer	Hewlett-Packard	dx2400 Microtower
Desktop	children5	Public Computer	Hewlett-Packard	dx2400 Microtower
Desktop	children7	Public Computer	Hewlett-Packard	dx2400 Microtower
Desktop	children8	Public Computer	Hewlett-Packard	dx2400 Microtower
Desktop	children9	Public Computer	Hewlett-Packard	dx2400 Microtower
Desktop	ellexp2	Public Computer	Hewlett-Packard	dx2400 Microtower
Desktop	ellexp3	Public Computer	Hewlett-Packard	dx2400 Microtower
Desktop	ellexp4	Public Computer	Hewlett-Packard	dx2400 Microtower
Desktop	ellpub1	Public Computer	Hewlett-Packard	dx2400 Microtower
Desktop	ellpub10	Public Computer	Hewlett-Packard	dx2400 Microtower
Desktop	ellpub2	Public Computer	Hewlett-Packard	dx2400 Microtower
Desktop	ellpub3	Public Computer	Hewlett-Packard	dx2400 Microtower
Desktop	ellpub4	Public Computer	Hewlett-Packard	dx2400 Microtower
Desktop	ellpub5	Public Computer	Hewlett-Packard	dx2400 Microtower
Desktop	ellpub6	Public Computer	Hewlett-Packard	dx2400 Microtower
Desktop	ellpub9	Public Computer	Hewlett-Packard	dx2400 Microtower
Desktop	inpub01	Public Computer	Hewlett-Packard	Pro 6305 MT
Desktop	inpub02	Public Computer	Hewlett-Packard	Pro 6305 MT
Desktop	ell-prs1	Reservation/Print Release	Hewlett-Packard	AY633AAR-ABA p6313w
Desktop	ellsignup2	Reservation/Print Release	Hewlett-Packard	dx2400 Microtower
Desktop	levelup-prs	Reservation/Print Release	Hewlett-Packard	dx2400 Microtower
Desktop	main-prs1	Reservation/Print Release	Hewlett-Packard	dx2400 Microtower PC
Desktop	main-prs2	Reservation/Print Release	Hewlett-Packard	AY014AAR-ABA a4310f
Desktop	mainsignup1	Reservation/Print Release	Hewlett-Packard	Pro 3130 Microtower PC
Desktop	selfcheck17	Self-Checkout	NCR	7409-1705-8801
Desktop	selfcheck18	Self-Checkout	NCR	7409-1705-8801
Desktop	selfcheck19	Self-Checkout	NCR	7409-1705-8801
Desktop	selfcheck20	Self-Checkout	NCR	7409-1705-8801
Desktop	selfcheck21	Self-Checkout	NCR	7409-1705-8801
Desktop	selfcheck23	Self-Checkout	NCR	7409-1705-8801
Desktop	selfcheck24	Self-Checkout	NCR	7409-1705-8801
Desktop	selfcheck26	Self-Checkout	NCR	7409-1725-8801
Desktop	selfcheck27	Self-Checkout	NCR	7409-1725-8801
Desktop	selfcheck28	Self-Checkout	NCR	7409-1725-8801
Desktop	selfcheck29	Self-Checkout	NCR	7409-1725-8801
Server	bedrock	Server	Hewlett-Packard	
Server	buck	Server	Dell	PowerEdge 1750

Server	callxpress	Server	Intel	D915PGN
Server	contact	Server	ASUSTeK Computer	CM6630_CM6730_CM6830.
Server	emerson	Server	Dell	PowerEdge R420
Server	herbert	Server	Hewlett-Packard	ProLiant DL320e Gen8 v2
Server	isdept	Server	Hewlett-Packard	dc5800 Microtower
Server	isdept2	Server	Generic	P8H61-M
Server	lovecraft	Server	Dell	PowerEdge R300
Server	mcpldev	Server	Dell	PowerEdge 2900
Server	mcplpac	Server	Dell	PowerEdge R320
Server	mcplpacold	Server	Dell	PowerEdge 1950
Server	mcplprod	Server	Dell	PowerEdge T710
Server	mcpltele	Server	Dell	PowerEdge 2900
Server	mcpltele2	Server	Dell	PowerEdge R320
Server	mcplterm	Server	Dell	PowerEdge 850
Server	mcpltrain	Server	Dell	PowerEdge 2900
Server	weaver	Server	Dell	PowerEdge R510
Server	whitman	Server	Dell	PowerEdge 2850
Desktop	accounting2	Staff Computer	Hewlett-Packard	Pro 6305 MT
Desktop	accounting3	Staff Computer	Hewlett-Packard	dx2400 Microtower PC
Desktop	adltref1	Staff Computer	Generic	P8H61-M
Desktop	adltref2	Staff Computer	Hewlett-Packard	Pro 3130 Microtower PC
Desktop	adltref3	Staff Computer	Hewlett-Packard	dx2400 Microtower PC
Desktop	adltref4	Staff Computer	Hewlett-Packard	dx2400 Microtower PC
Desktop	adltstaff1	Staff Computer	Hewlett-Packard	Pro 3130 Microtower PC
Desktop	adltstaff12	Staff Computer	Hewlett-Packard	AY633AAR-ABA p6313w
Desktop	adltstaff17	Staff Computer	Generic	P8H61-M
Desktop	adltstaff19	Staff Computer	Hewlett-Packard	Pro 6305 MT
Desktop	adltstaff2	Staff Computer	Hewlett-Packard	AY014AAR-ABA a4310f
Desktop	adltstaff20	Staff Computer	Hewlett-Packard	Pro 3500 Series
Desktop	adltstaff21	Staff Computer	Hewlett-Packard	Pro 3500 Series
Desktop	adltstaff22	Staff Computer	Hewlett-Packard	Pro 3500 Series
Desktop	adltstaff23	Staff Computer	Generic	P8H61-M
Desktop	adltstaff26	Staff Computer	Hewlett-Packard	Pro 6305 MT
Desktop	adltstaff3	Staff Computer	Generic	P8H61-M
Desktop	adltstaff33	Staff Computer	Hewlett-Packard	Pro3500 Series
Desktop	adltstaff5	Staff Computer	Hewlett-Packard	Pro 3500 Series
Desktop	adltstaff6	Staff Computer	Hewlett-Packard	Pro3500 Series
Desktop	adltstaff8	Staff Computer	Hewlett-Packard	Pro 3130 Microtower PC

Desktop	adminstaff10	Staff Computer	Hewlett-Packard	Pro 3130 Microtower PC
Desktop	adminstaff11	Staff Computer	Generic	P8H61-M
Desktop	adminstaff12	Staff Computer	Generic	P8H61-M
Desktop	adminstaff15	Staff Computer	Hewlett-Packard	AY014AAR-ABA a4310f
Desktop	adminstaff20	Staff Computer	Generic	System Product Name
Desktop	adminstaff6	Staff Computer	Hewlett-Packard	Pro3500 Series
Desktop	adminstaff7	Staff Computer	Hewlett-Packard	Pro 3500 Series
Desktop	adminstaff9	Staff Computer	Hewlett-Packard	AY014AAR-ABA a4310f
Desktop	adultstaff5	Staff Computer	Hewlett-Packard	Pro 3130 Microtower PC
Desktop	adultstaff6	Staff Computer	Generic	P8H61-M
Desktop	ats-ill	Staff Computer	Hewlett-Packard	AY014AAR-ABA a4310f
Desktop	bcat2	Staff Computer	Hewlett-Packard	Pro 3500 Series
Desktop	bedrockpc	Staff Computer	Hewlett-Packard	AY014AAR-ABA a4310f
Desktop	bookscanell	Staff Computer	Elo TouchSystems	ESYxxBx
Desktop	bookscanstation	Staff Computer	Elo TouchSystems	ESYxxBx
Desktop	bookstore	Staff Computer	Generic	System Product Name
Desktop	bookstore2	Staff Computer	Hewlett-Packard	dx2400 Microtower PC
Desktop	buck7	Staff Computer	Dell	OptiPlex GX620
Desktop	busistaff1	Staff Computer	Hewlett-Packard	Pro 3130 Microtower PC
Desktop	callcenter1	Staff Computer	Hewlett-Packard	Pro 3500 Series
Desktop	callcenter2	Staff Computer	Hewlett-Packard	Pro 3500 Series
Desktop	callcenter3	Staff Computer	Hewlett-Packard	Pro3500 Series
Desktop	camera	Staff Computer	Hewlett-Packard	dx2400 Microtower
Desktop	cats-03	Staff Computer	Dell	OptiPlex GX240
Desktop	cats2	Staff Computer	Apple	
Desktop	catscontrol	Staff Computer	Hewlett-Packard	AY633AAR-ABA p6313w
Desktop	catsmanager	Staff Computer	Hewlett-Packard	dx2400 Microtower
Desktop	catstime	Staff Computer	Hewlett-Packard	dx2400 Microtower
Desktop	cd-staff12	Staff Computer	Generic	P8H61-M
Desktop	cd-staff13	Staff Computer	Hewlett-Packard	Pro 3130 Microtower PC
Desktop	cd-staff14	Staff Computer	Hewlett-Packard	Pro 3500 Series
Desktop	cd-staff15	Staff Computer	Hewlett-Packard	Pro3500 Series
Desktop	cd-staff20	Staff Computer	Hewlett-Packard	Pro3500 Series
Desktop	cd-staff22	Staff Computer	Hewlett-Packard	Pro 6305 MT
Desktop	cd-staff5	Staff Computer	Hewlett-Packard	Pro 3130 Microtower PC
Desktop	cd-staff6	Staff Computer	Generic	P8H61-M
Desktop	cd-staff7	Staff Computer	Hewlett-Packard	Pro 3500 Series
Desktop	chldref1	Staff Computer	Generic	System Product Name

Desktop	chldref2	Staff Computer	Hewlett-Packard	Pro 3500 Series
Desktop	chldref3	Staff Computer	Generic	System Product Name
Desktop	chldref4	Staff Computer	Hewlett-Packard	Pro 3130 Microtower PC
Desktop	chldstaff1	Staff Computer	Hewlett-Packard	AY633AAR-ABA p6313w
Desktop	chldstaff12	Staff Computer	Hewlett-Packard	AY014AAR-ABA a4310f
Desktop	chldstaff14	Staff Computer	Hewlett-Packard	Pro 6305 MT
Desktop	chldstaff15	Staff Computer	Hewlett-Packard	Pro 6305 MT
Desktop	chldstaff16	Staff Computer	Hewlett-Packard	Pro3500 Series
Desktop	chldstaff17	Staff Computer	Hewlett-Packard	Pro3500 Series
Desktop	chldstaff18	Staff Computer	Hewlett-Packard	Pro3500 Series
Desktop	chldstaff23	Staff Computer	Hewlett-Packard	Pro3500 Series
Desktop	chldstaff4	Staff Computer	Hewlett-Packard	Pro3500 Series
Desktop	chldstaff9	Staff Computer	Generic	System Product Name
Desktop	circ02	Staff Computer	Hewlett-Packard	Pro3500 Series
Desktop	circ111	Staff Computer	Hewlett-Packard	Pro 3130 Microtower PC
Desktop	circ18	Staff Computer	Hewlett-Packard	AY633AAR-ABA p6313w
Desktop	circ22	Staff Computer	Generic	P8H61-M
Desktop	circ26	Staff Computer	Hewlett-Packard	Pro 3500 Series
Desktop	circ43	Staff Computer	Hewlett-Packard	Pro 3130 Microtower PC
Desktop	circ7	Staff Computer	Hewlett-Packard	Pro 6305 MT
Desktop	circoffice8	Staff Computer	Generic	P8H61-M
Desktop	circopac1	Staff Computer	Hewlett-Packard	AY633AAR-ABA p6313w
Desktop	circopac2	Staff Computer	Hewlett-Packard	AY633AAR-ABA p6313w
Desktop	circime	Staff Computer	Generic	P8H61-M
Desktop	circulation2	Staff Computer	Hewlett-Packard	Pro 3500 Series
Desktop	circulation36	Staff Computer	Hewlett-Packard	dc5800 Microtower
Desktop	circulation37	Staff Computer	Generic	P8H61-M
Desktop	dell75	Staff Computer	Hewlett-Packard	dx2400 Microtower PC
Desktop	elletts01	Staff Computer	Hewlett-Packard	dx2400 Microtower
Desktop	elletts02	Staff Computer	Hewlett-Packard	AY014AAR-ABA a4310f
Desktop	ellettscirc2	Staff Computer	Hewlett-Packard	Pro3500 Series
Desktop	ellettscirc3	Staff Computer	Hewlett-Packard	Pro3500 Series
Desktop	ellettscirc4	Staff Computer	Hewlett-Packard	Pro3500 Series
Desktop	ellref2	Staff Computer	Hewlett-Packard	Pro 3130 Microtower PC
Desktop	ellref3	Staff Computer	Hewlett-Packard	Pro3500 Series
Desktop	ellstaff1	Staff Computer	Hewlett-Packard	Pro 3500 Series
Desktop	ellstaff18	Staff Computer	Generic	P8H61-M
Desktop	ellstaff44	Staff Computer	Generic	P8H61-M

Desktop	ellstaff55	Staff Computer	Generic	P8H61-M
Desktop	facilities1	Staff Computer	Generic	System Product Name
Desktop	facilities2	Staff Computer	Hewlett-Packard	Pro3500 Series
Desktop	facilities3	Staff Computer	Generic	P8H61-M
Desktop	hr-kyle3	Staff Computer	Hewlett-Packard	Pro3500 Series
Desktop	hr-marla3	Staff Computer	Generic	System Product Name
Desktop	hrstaff	Staff Computer	Hewlett-Packard	dx2400 Microtower PC
Desktop	hugo2	Staff Computer	Hewlett-Packard	Pro3500 Series
Desktop	indianaroom1	Staff Computer	Hewlett-Packard	dx2400 Microtower
Desktop	indianaroom2	Staff Computer	Hewlett-Packard	dx2400 Microtower
Desktop	indianaroomv	Staff Computer	Hewlett-Packard	dx2400 Microtower
Desktop	indianascanner	Staff Computer	Hewlett-Packard	dx2400 Microtower
Desktop	indrmmanager	Staff Computer	Hewlett-Packard	Pro 3500 Series
Desktop	indrmref1	Staff Computer	Hewlett-Packard	Pro3500 Series
Desktop	indrmref2	Staff Computer	Hewlett-Packard	Pro 3130 Microtower PC
Desktop	indroom11	Staff Computer	Hewlett-Packard	Pro 3130 Microtower PC
Desktop	intern1	Staff Computer	Hewlett-Packard	dx2400 Microtower
Desktop	isdept10	Staff Computer	Hewlett-Packard	dc7900 Convertible Minitower
Desktop	isdept11	Staff Computer	Hewlett-Packard	AY633AAR-ABA p6313w
Desktop	isdept29	Staff Computer	Hewlett-Packard	Pro 3130 Microtower PC
Desktop	isdept32	Staff Computer	Hewlett-Packard	Pro 3500 Series
Desktop	isdept40	Staff Computer	Hewlett-Packard	dx2400 Microtower
Desktop	isdept47	Staff Computer	Hewlett-Packard	Pro3500 Series
Desktop	isdept52	Staff Computer	Hewlett-Packard	Pro3500 Series
Desktop	isdept53	Staff Computer	Hewlett-Packard	Pro3500 Series
Desktop	isdept7	Staff Computer	Hewlett-Packard	AY014AAR-ABA a4310f
Desktop	isdept-macmini	Staff Computer	Apple	Mac mini
Desktop	mcpl-laptop30	Staff Computer	Dell	XPS 13 9343
Desktop	mcpl-laptop31	Staff Computer	Dell	XPS 13 9343
Desktop	oldadult11	Staff Computer	Hewlett-Packard	Pro 3130 Microtower PC
Desktop	oldadult16	Staff Computer	Hewlett-Packard	dx2400 Microtower
Desktop	oldadult17	Staff Computer	Hewlett-Packard	dx2400 Microtower
Desktop	oldadult33	Staff Computer	Hewlett-Packard	dx2400 Microtower
Desktop	outreach10	Staff Computer	Hewlett-Packard	AY633AAR-ABA p6313w
Desktop	outreach3	Staff Computer	Hewlett-Packard	Pro 3500 Series
Desktop	outreach4	Staff Computer	Hewlett-Packard	Pro 3500 Series
Desktop	outreach6	Staff Computer	Hewlett-Packard	Pro 3500 Series
Desktop	outreach8	Staff Computer	Generic	P8H61-M

Desktop	penny	Staff Computer	Hewlett-Packard	AY014AAR-ABA a4310f
Desktop	roofstaff2	Staff Computer	Hewlett-Packard	dx2400 Microtower
Desktop	rooftime	Staff Computer	Dell	OptiPlex 745
Desktop	rooftime2	Staff Computer	Hewlett-Packard	dx2400 Microtower
Desktop	security06	Staff Computer	Hewlett-Packard	Pro 6305 MT
Desktop	security2ndfl	Staff Computer	Hewlett-Packard	Pro 3500 Series
Desktop	securityfirstfl	Staff Computer	Hewlett-Packard	AY014AAR-ABA a4310f
Desktop	securityoffice	Staff Computer	Generic	P8H61-M
Desktop	stafflounge3	Staff Computer	Generic	P8H61-M
Desktop	teen1	Staff Computer	Hewlett-Packard	Pro3500 Series
Desktop	tester1	Staff Computer	Hewlett-Packard	Pro 3130 Microtower PC
Desktop	vitalstaff1	Staff Computer	Generic	System Product Name
Desktop	vitalstaff3	Staff Computer	Hewlett-Packard	Pro 3500 Series
Desktop	vitalstaff4	Staff Computer	Hewlett-Packard	Pro 6305 MT
Laptop	adminstafflaptop	Staff Computer	Hewlett-Packard	ProBook 4530s
Laptop	ann-laptop	Staff Computer	Hewlett-Packard	Stream Notebook PC 13
Laptop	champelli	Staff Computer	Dell	Latitude E7440
Laptop	ell-winbook-01	Staff Computer	Apple	MacBookPro11,1
Laptop	ell-winbook-02	Staff Computer	Apple	MacBookPro11,1
Laptop	ell-winbook-03	Staff Computer	Apple	MacBookPro11,1
Laptop	ell-winbook-04	Staff Computer	Apple	MacBookPro11,1
Laptop	ell-winbook-05	Staff Computer	Apple	MacBookPro11,1
Laptop	ell-winbook-06	Staff Computer	Apple	MacBookPro12,1
Laptop	ell-winbook-07	Staff Computer	Apple	MacBookPro12,1
Laptop	ell-winbook-08	Staff Computer	Apple	MacBookPro12,1
Laptop	ell-winbook-09	Staff Computer	Apple	MacBookPro12,1
Laptop	ell-winbook-10	Staff Computer	Apple	MacBookPro12,1
Laptop	galarza	Staff Computer	Dell	Latitude E7440
Laptop	hoffman	Staff Computer	Dell	Latitude E7440
Laptop	homework01	Staff Computer	Lenovo	Lenovo G550
Laptop	homework02	Staff Computer	Lenovo	Lenovo G550
Laptop	homework03	Staff Computer	Lenovo	Lenovo G550
Laptop	homework04	Staff Computer	Lenovo	Lenovo G550
Laptop	homework05	Staff Computer	Lenovo	Lenovo G550
Laptop	homework06	Staff Computer	Lenovo	Lenovo G550
Laptop	homework07	Staff Computer	Lenovo	Lenovo G550
Laptop	homework08	Staff Computer	Lenovo	Lenovo G550
Laptop	homework09	Staff Computer	Lenovo	Lenovo G550

Laptop	homework10	Staff Computer	Lenovo	Lenovo G550
Laptop	homework11	Staff Computer	Lenovo	Lenovo G550
Laptop	homework12	Staff Computer	Lenovo	Lenovo G550
Laptop	homework13	Staff Computer	Lenovo	Lenovo G550
Laptop	homework14	Staff Computer	Lenovo	Lenovo G550
Laptop	isdept38	Staff Computer	Hewlett-Packard	ProBook 4530s
Laptop	isdept44	Staff Computer	Hewlett-Packard	ProBook 450 G2
Laptop	isdept6	Staff Computer	Hewlett-Packard	ProBook 4530s
Laptop	isdepttouchlapt	Staff Computer	Lenovo	ThinkPad Edge E431
Laptop	is-laptop3	Staff Computer	Hewlett-Packard	ProBook 4530s
Laptop	it-laptop01	Staff Computer	Hewlett-Packard	Stream Notebook PC 13
Laptop	it-laptop03	Staff Computer	Hewlett-Packard	Stream Notebook PC 13
Laptop	it-temp-laptop1	Staff Computer	Dell	Latitude E7440
Laptop	mcpl_surface1	Staff Computer	Microsoft	Surface Pro 3
Laptop	mcpl-laptop13	Staff Computer	Dell	Latitude D505
Laptop	mcpl-laptop22	Staff Computer	Hewlett-Packard	ProBook 4520s
Laptop	mcpl-laptop23	Staff Computer	Hewlett-Packard	ProBook 4520s
Laptop	mcpl-laptop24	Staff Computer	Hewlett-Packard	ProBook 4520s
Laptop	mcpl-laptop27	Staff Computer	Hewlett-Packard	ProBook 4520s
Laptop	trainingwin01	Staff Computer	Apple	MacBookPro11,1
Laptop	trainingwin02	Staff Computer	Apple	MacBookPro11,1
Laptop	trainingwin03	Staff Computer	Apple	MacBookPro11,1
Laptop	trainingwin04	Staff Computer	Apple	MacBookPro11,1
Laptop	trainingwin05	Staff Computer	Apple	MacBookPro11,1
Laptop	trainingwin06	Staff Computer	Apple	MacBookPro11,1
Laptop	trainingwin07	Staff Computer	Apple	MacBookPro11,1
Laptop	trainingwin08	Staff Computer	Apple	MacBookPro11,1
Laptop	trainingwin09	Staff Computer	Apple	MacBookPro11,1
Laptop	trainingwin10	Staff Computer	Apple	MacBookPro11,1
Laptop	vital-laptop	Staff Computer	Dell	Latitude E6500
Laptop	vital-laptop2	Staff Computer	Hewlett-Packard	ProBook 4520s

**MONROE COUNTY PUBLIC LIBRARY
2016 HOLIDAY CLOSING SCHEDULE**

January 1 (Friday)	NEW YEAR'S DAY
March 27 (Sunday)	SPRING HOLIDAY
May 30 (Monday)	MEMORIAL DAY
July 4 (Monday)	INDEPENDENCE DAY
September 5 (Monday)	LABOR DAY
November 24 (Thursday)	THANKSGIVING
November 25 (Friday)	
December 24 (Saturday)	WINTER HOLIDAY
December 25 (Sunday)	
December 31 (Saturday)	NEW YEAR'S EVE
<u>Close at 5:00 p.m.</u>	

2017

January 1, 2017 (Sunday)	NEW YEAR'S DAY
---------------------------------	-----------------------

**MONROE COUNTY PUBLIC LIBRARY
PAY SCHEDULE
2016**

December 14 – December 27, 2015	January 8
December 28 – January 10	January 22
January 11– January 24	February 5
January 25 – February 7	February 19
February 8 – February 21	March 4
February 22 – March 6	March 18
March 7 – March 20	April 1
March 21 – April 3	April 15
April 4 – April 17	April 29
April 18 – May 1	May 13
May 2 – May 15	May 27
May 16 – May 29	June 10
May 30 – June 12	June 24
June 13– June 26	July 8
June 27 – July 10	July 22
July 11 – July 24	August 5
July 25 – August 7	August 19
August 8 – August 21	September 2
August 22 – September 4	September 16
September 5 – September 18	September 30
September 19 – October 2	October 14
October 3 – October 16	October 28
October 17 – October 30	November 10
October 31 – November 13	November 25
November 14 – November 27	December 9
November 28 – December 11	December 23

2017

December 12 – December 25, 2016	January 6, 2017
---------------------------------	-----------------

MONROE COUNTY PUBLIC LIBRARY
Wage and Salary Schedule
2016

Pay Grade	Market Minimum	Market Maximum
Hourly / Non-Exempt		
1	\$9.00	\$13.50
2	\$9.97	\$14.96
3	\$11.68	\$17.52
4	\$12.69	\$19.04
5	\$13.91	\$20.87
6	\$15.03	\$22.55
7	\$16.57	\$24.86
Salaried / Exempt		
8	\$1,433.39	\$2,150.09
9	\$1,601.70	\$2,402.55
10	\$1,854.70	\$2,782.05
11	\$2,643.93	\$3,965.90

RESOLUTION TO ADOPT 2016 PAY SCHEDULE, WAGE and SALARY SCHEDULE, PAY INCREMENT, AND HOLIDAY CLOSING SCHEDULE

WHEREAS it has been determined that it is now necessary to adopt a Salary Schedule, Pay Schedule, and Holiday Closing Schedule for the 2016 fiscal year, and

WHEREAS the Board desires to adjust the Wage and Salary schedule in order to continue to attract and maintain the Library’s talent in a competitive market and to provide a cost of living increase to our valued staff who are employed at the Library as of December 31, 2015 and,

WHEREAS the board wishes to adjust the current minimums and maximums within the Wage and Salary Schedule based upon local market research, and provide a cost of living increase which falls within the amount budgeted for 2016,

NOW THEREFORE the Board adopts the 2016 Wage and Salary Schedule and approves a .75 cent or a 2.6% incremental increase per hour – whichever is greater – for all who are employed at the Library as of December 31, 2015 (effective for the first pay date of 2016 on January 08, 2016, which includes the pay period beginning December 14, 2015 and ending December 27, 2015); Pay Schedule, and Holiday Closing Schedule.

Presented to the Monroe County Public Library Board, read in full and adopted this 16th day of December, 2015, by the following aye and nay votes.

AYE

NAY

Monroe County Public Library 2016 Fee Schedule

Overdue fines	\$0.25/day (Maximum \$10/item) (No charge for children's materials)
Collection Agency Fee	\$10.00
Replacement Library Card	\$1.00
Annual Subscription Card – Non-resident	\$60.00
Lost items	Varies
Photocopies	\$0.10/page non-color, \$0.30/page color (Patrons granted \$0.30/day free reference material copies)
Printing	\$0.10/page non-color, \$0.30/page color (Patrons granted \$0.30/day free printing)
Obituaries supplied for out-of-county residents	\$3/name
Genealogy research for out-of-county residents	\$10/request
Meeting room and auditorium rental for businesses operating in Monroe County	\$150/hour for Auditorium and for 1B/1C combined \$75/hour for 1B, 1C, 2A
Meeting room clean-up fee	Maintenance (reset room, clean carpet, repair furniture, etc.): \$25/hour. Equipment damage or replacement: Cost + \$10 service fee
CATS dubs	\$10/dub (No charge for dubs of public meetings for elected officials from units with contracts with CATS)
Fine Option Program (for patrons 14+)	\$5/hour credit
Read It Off (children under age 18)	\$5/use and return
Food for Fines credit	\$1 for each item

Revised January 2013; August 2013; December 2013; December 2014; December 2015

